

Ballistocardiograph

In this lab you will construct a circuit which can sense your heart rate from an ordinary bathroom scale. Known as a ballistocardiograph (BCG), the principle is that the reaction force at the ground fluctuates a little bit as the heart impulsively ejects blood with each beat. There is a slight recoil which we can sense. The principle is the same as if you stand on a scale and flap your arms, the weight the scale reads will go up and down. Since the measurement is so sensitive, we can do a simultaneous EKG which will help us identify and correlate the two signals, shown below in Figure 1.

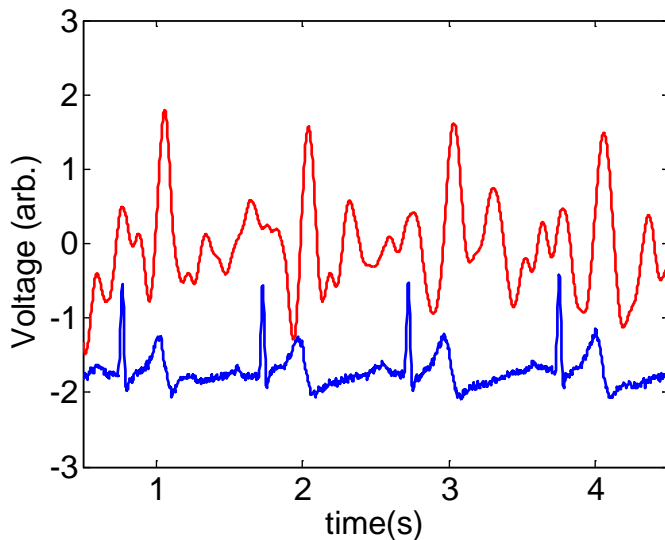

Figure 1: Comparison of EKG (blue) and BCG (red) signal. Note the regular correlation between the second hump of the EKG signal and the impulse from the BCG.

The basic principle of the circuit is that we must very aggressively filter out both the noise at high frequencies (in this case, high relative to the ~ 1 Hz signal), the DC offset from your constant mass, and the low frequency oscillations due to your balance which is never stationary. The filters must have a narrow frequency response in order to isolate your pulse. It is important in this circuit that you keep your wires clipped short and close to the breadboard. Noise will ruin your circuit.

Since there are only a few scales to share among the class, you will need to build and debug your circuit and then come to the front of the class to test. **PLEASE be reasonably gentle and respectful of the scales. While they are not that fragile, they can be damaged if the wires are pulled on, or they are not treated with a bit of care. Please remember that other people need to finish the lab so it would be nice to complete the week with the same number of functional setups that we started with. Last year someone stole one of the scales. Please do not steal from us.**

A block diagram of the circuit is shown below in Figure 2. Since each block is essentially buffered by an op-amp, the blocks do not interact with each other and can be built, tested, and analyzed in isolation. You should build each block in turn and then test after each new additional block.

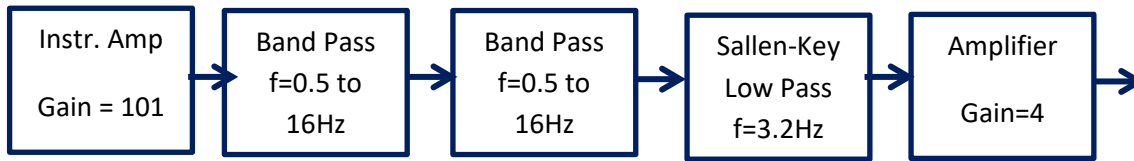

Figure 2: Block diagram of your circuit.

The basic principle of the bathroom scale is the use of the strain gauge to measure the weight – just as you did earlier in the semester. The first step is to use the instrumentation amplifier, more or less the same as the strain gauge lab. The main difference is that the resistors for the bridge are the strain gauges located in the each of the four legs of the bathroom scale. In the strain gauge lab, 1 resistor in the bridge was a strain gauge while the other 3 were fixed resistors. In the scale, the strain gauges are internal to the mechanical system and the 4 four wires come out can be wired as shown in Figure 3. Since the strain gauges are more precisely manufactured than standard resistors, there is no need to balance the bridge with a potentiometer. You will also note that there are some resistors and capacitors at the front end of the circuit. This arrangement is suggested by the manufacturer of the instrumentation amplifier chip to reduce RF interference. Since there is a fair amount of electrical noise in our room the overall performance seems much improved with this circuit up front. You should also note that the strain gauge is powered with the 2.5 V reference. This choice was made as the 2.5 volt reference is much more stable than the 5V from your USB. The 2.5 volt reference is not able to supply much current, however in this case the resistance of the strain gauges limits the current to less than 1 mA, which is acceptable for the voltage reference

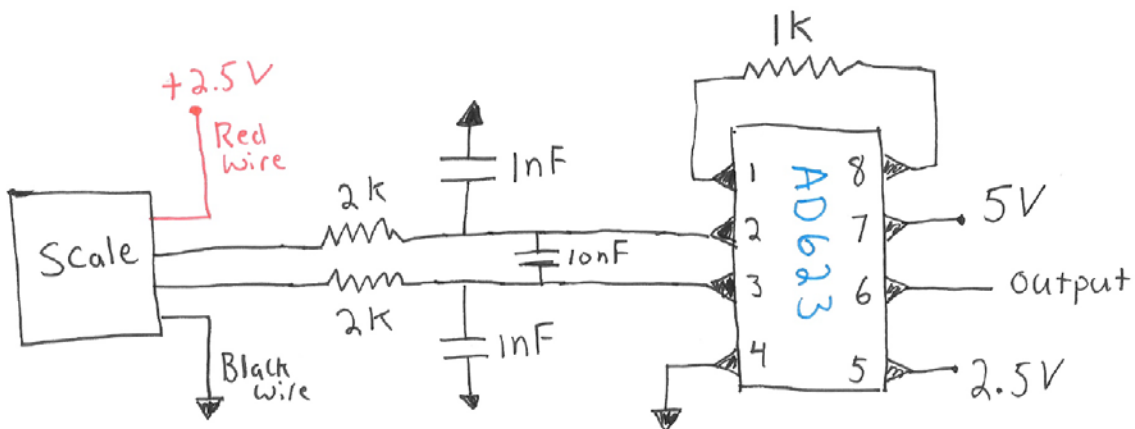

Figure 3: First stage of the circuit. Instrumentation amplifier interfacing with the strain gauges in the scale. The strain gauges inside the scale form the Wheatstone bridge. Note that the scales will have four wires coming out of them. The red wire should go to 2.5V and the black at ground.

At this point you may want to test the circuit quickly using one of the scales. The output signal at this point will be a voltage proportional to the weight on the scale. If you measure the output of the instrumentation amplifier and stand on the scale, you should see a voltage change. The output voltage when there is no load should be close to zero but not exactly (maybe a few hundred mV). This offset

voltage has to do with some slight imbalance of the bridge resistors. When you stand on the scale, the voltage may go positive or negative depending on which wire goes into the positive input of the instrumentation amplifier – it doesn't matter. At this point if you see changes when you load the scale of 10-50 mV, you are probably on the right track.

The next stage consists of two bandpass filters with cutoff frequencies of 0.5 and 16 Hz, Figure 4. We cascade two of the same filters in series such that we obtain a second order roll off above or below the cutoff frequencies. By second order roll-off we mean that for every factor of 10 in frequency that we exceed the cutoff value, the output signal decreases by a factor of 100. Each of these two filters also has a gain of 33 built into it. Test each filter in isolation of the scale using the network analyzer on the Analog Discovery. **Include one of the Bode plots of the single filter in your lab report**, but test both individually. Note that the filters are referenced to 2.5 volts and have high gain, so your input signal for the network analyzer should be offset to 2.5 V and of something like 50mV. Note that we haven't quite yet discussed in class how to analyze the circuit in Figure 4. For now, characterize them experimentally and we will analyze them in coming weeks.

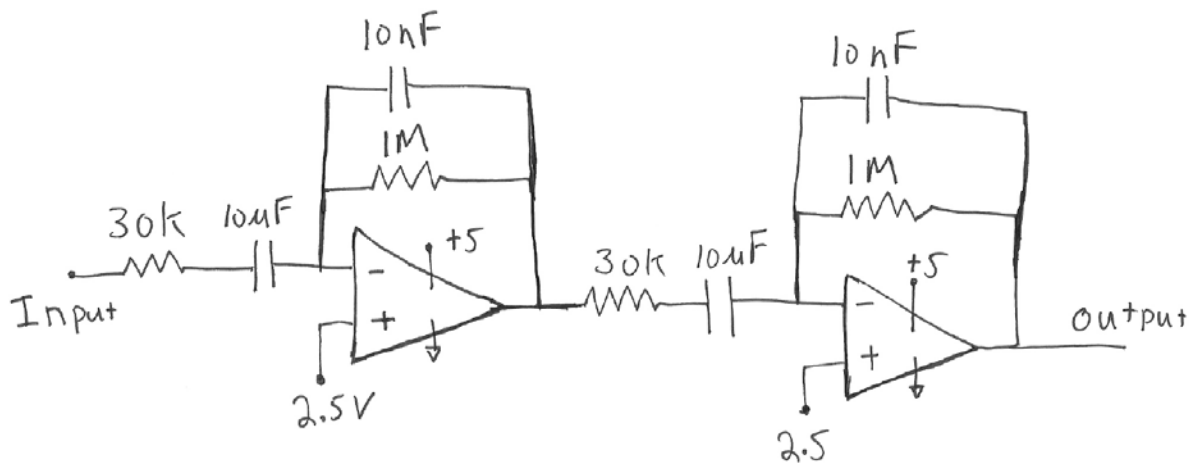

Figure 4: Two bandpass filters with cutoff frequencies of 0.5 and 16 Hz and a gain of 33.

At this stage, you could also check the circuit with the scale attached. If you hook the scale up, you should see that the circuit is very sensitive to light tapping on the scale. If you monitor the output of the second op-amp in Figure 4, it should be sensitive to light tapping around once per second. You don't need to include this result in your lab report – it's just for you to test as you go.

Now build the final stage. This consists of a second order low-pass filter with a cutoff frequency of 3.2 Hz. The topology of the circuit shown with op-amp C in Figure 5 is called the Sallen-Key topology. We have not discussed this circuit in class, but it has a second order roll off above 3.2 Hz. We will analyze this circuit more next week. Test the filter in isolation with the network analyzer and include the **Bode**

plot in your lab report. Finally, with op-amp D we have a gain of 4. For your setup you may need/want to adjust the amplification factor. You may find you get a satisfactory signal out of op-amp C.

Once you have the entire circuit built, you can try to test with one of the scales. The scale should be very sensitive to just a light tap with your finger. If the signal does not respond to a light tap, then it will not work when you stand on it.

Finding your heart rate is challenging, so you have to do this with care. Some tips are

- Keep the scale on a hard surface.
- Hold very still. It is hard to get more than 4 or 5 clean beats in a row before you wobble and swamp the signal.
- If you find the electrical noise in the lab is too much, try the hallway with your laptop on battery, though you will need to place the scale on a hard surface.
- Place your fingers on your wrist to find your pulse, you can often see the peaks of the BCG signal correlating with your pulse.

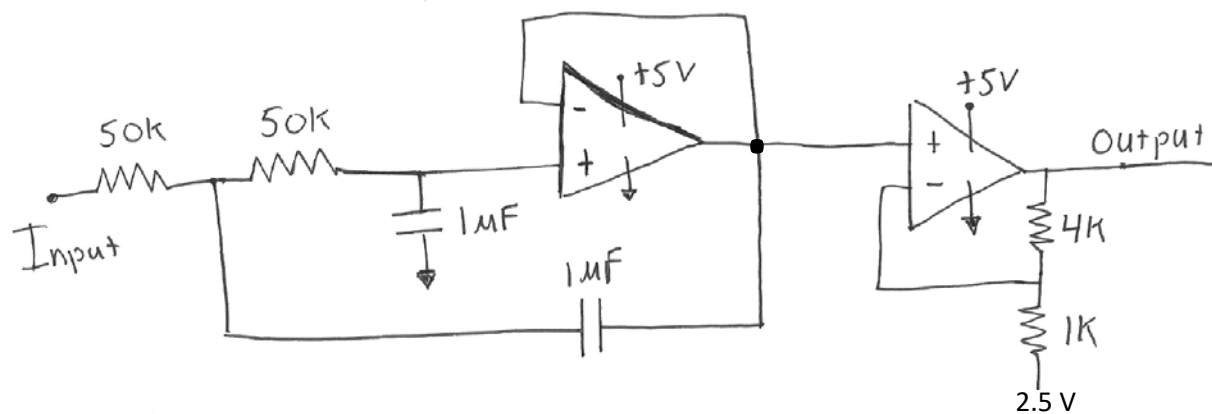

Figure 5: Sallen-Key second order low-pass filter with a cutoff frequency of 3.2 Hz. The amplifier following this filter has a gain of 4 set here, but you may find you want to adjust this value.

Deliverables

1. The Bode plots of the filter stages as requested above. YOU DO NOT NEED TO HAVE AN ANALYSIS OF THIS FILTER AS YOU DON'T YET KNOW HOW TO DO IT, however, you should be able to identify the important frequencies given by the RC values of the circuit.
2. A good clean BCG trace, similar to what is shown in Figure 1.
3. A picture of your beautiful circuit.

Since the circuit this week is our most complicated to build to date, we will wait to analyze the filter elements next week. Also, note that this lab report will be VERY SHORT. Just a few results along the way and the finale. Since you don't know how to analyze the filters just yet, you only need to provide the experimental results. You don't need any analysis this week.