

EKG

We are going to build a fully-operational 3-wire EKG instrument. The three-wire connection is the simplest that will yield a usable trace (not just a heart rate). The resulting EKG will reveal all the electrical activity of the heart. A full diagnosis involves the connection of 12 electrodes across the chest and on the extremities. We will only be connecting electrodes to the arms.

<http://en.wikipedia.org/wiki/Electrocardiography>

Disclaimer

WE ARE NOT MEDICAL DOCTORS and neither are you. Please don't attempt to interpret anything other than possibly your heart rate (beats per minute) from your EKG.

About Safety

We are performing an Association for Advancement of Medical Instrumentation (AAMI) Type B connection to the body, since we are potentially connecting a direct ground to the patient (you). This is considered risky because of the possibility of a ground loop if any other instrumentation is connected that may have a different ground connection. Our ground connection is established through the 5 VDC USB power supply in your notebook computer, which may (but usually doesn't) connect to the building wiring ground via the power brick's wall plug ground prong. To fully comply with AAMI recommendations:

1. **Unplug the power brick from your notebook computer, and run the notebook on its batteries during the EKG experiment.** This converts the connection to a Type BF (fully floating) connection.
2. Don't connect yourself to any other AC-powered instrumentation while you are doing this experiment. Do not connect yourself to ground by holding onto an earth connection such as a water fixture.

While it would be extremely unlikely for a failure to occur whereby you could be injured by the electrical connection through the computer's USB, please unplug your laptop to comply with the AAMI regulations.

About Privacy

If you are AT ALL concerned about submitting your personal EKG with your lab report, YOU DO NOT HAVE TO DO SO. The EKG plot could be construed as medical information protected under Federal HIPAA privacy laws, i.e.,

<http://www.hhs.gov/ocr/privacy/hipaa/understanding/index.html>.

You may borrow one of the instructors who will serve as your patient if you wish.

The EKG circuit

The EKG circuit is really quite simple. We will make use of the same instrumentation amplifier chip you used in the strain gauge lab, the AD623 by Analog Devices. The connection diagram is shown below:

CONNECTION DIAGRAM

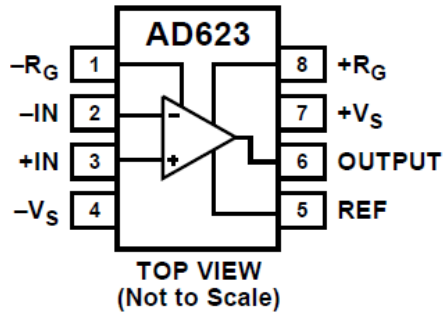

As you have seen, the chip is very easy to use. You simply place a resistor between pins 1 and 8 to set the gain of the amplifier. If you look through the data sheet you will find that the gain resistor, R_G , is related to the amplifier gain G , by $R_G = 100 \text{ k}\Omega / (G - 1)$. The chip provides an output which is simply, $V_{out} = V_{ref} + G(V_{in+} - V_{in-})$. Pin 5, the reference, is the output voltage when there is no difference at the inputs. We will set the reference voltage to 2.5. This way, we get 2.5 volts when the inputs are equal and have room with the 0-5 V power to have the voltage difference of the inputs to be positive or negative. If we used the ground as the reference, then we would only be able to see anything when the positive input was greater than the negative one.

The entire schematic is shown below. Note that the filters we are using for the EKG use larger capacitors than in the warmup exercises in order to adjust the characteristic frequency to the appropriate range. We used a higher frequency in the warmup exercises. For the EKG we need to isolate the approximately 1 Hz heartbeat signal. You need to pay careful attention to component values to get this circuit to work.

There are many possible variations of this EKG circuit that would probably work equally as well as the one here. We have used two stages of amplification as there is typically some constant offset in the EKG that is best to remove with a high pass filter before full amplification. All the amplification in the first stage tends to saturate the signal. Here we selected the first amplification stage with a gain of 201 and the second stage an amplification of 11. It is possible that you may want to adjust these for yourself as each of you will have a different signal. The use of 1 low pass and 3 high pass filters seems to work well, though the EKG signal is observable with less filtering and may even be somewhat apparent in your raw signal after the first instrumentation amplifier.

Testing the EKG

To connect to the circuit you will need a patient (yourself if you would like, or one of the course instructors), three of the adhesive electrode pads, and three alligator clip leads. Two of the pads should be placed on the inside of the wrist or inside of the elbow. The inner elbow works well as the electrodes tend to stay put (they may wiggle off and make a poor connection on the wrist), while the wrist is convenient if you are wearing long sleeves. The third ground electrode can be on the back of your hand. The alligator clip leads will connect

to the metal tab on the electrodes. The other end can grab a set of header pins to connect to your breadboard. Your ground electrode on the back of your hand should connect directly to the ground on the breadboard. The wrists should connect to the AD623 through the 100K resistor. The 100 K resistor is for safety to isolate you from the power sources. This extra resistor is to comply with medical electronics standards; the risk of shock through the computers USB power supply is exceedingly low.

For your lab writeup you need to include a snapshot of a reasonably clean EKG, so be sure to save some data before you close down for the day. See below for a sample of what a “good” trace looks like. You will also include a photo of your working circuit on the breadboard.

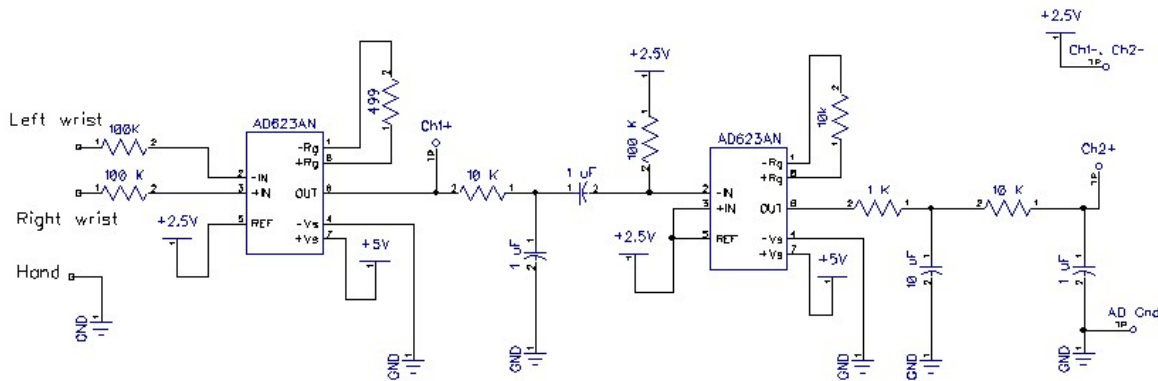

Figure 1: EKG circuit.

Deliverables

You should include a clean EKG trace a picture of your beautiful, clean circuit with no long loopy wires.

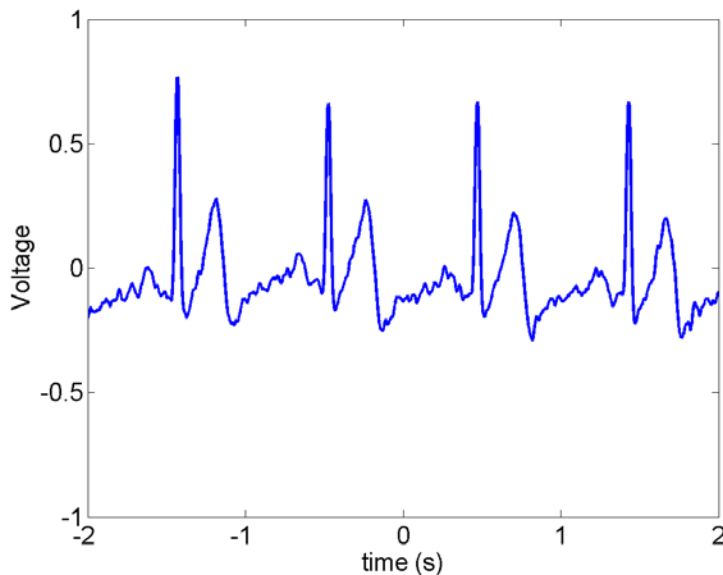

Figure 2: Sample EKG trace.