

Glucose meter

In this lab we will build a blood glucose meter, similar to the commercial devices that are used to monitor glucose levels in patients with diabetes. Diabetes is a serious disease which affects nearly 400 million people worldwide, is the 8th leading cause of death, and costs the US nearly \$250 billion a year. These glucose meters play a very important role in managing diabetes as they provide the patient the ability to monitor their glucose levels from home and at any time of the day. If you look in the pharmacy you will find a number of hand-held meters and accompanying test strips. Typically, the patient would insert one of the disposable test strips into the meter, prick their finger, load a droplet of blood into the test strip, wait a few seconds and get an instant reading of the current glucose level. In our lab, we will use a set of commercial test strips and build our own circuitry to measure the glucose levels. Our glucose meter will use a water-glucose solution of known concentration as a stand-in for blood. We don't want you to prick your finger or deal with blood all over our lab!

The basic principle of operation is as follows. A set of electrodes are printed into the test strips. A fixed voltage is applied (either constant or in a known sequence) and the resulting current and its response is monitored. The current response is then related to the glucose concentration through calibration. Typically the electrodes are coated such that an enzymatic chemical reaction occurs at the electrode surface and this reaction dictates the resulting current. The details of the electrochemistry can be quite complex. Since we are using commercial strips, the details are somewhat unknown as the companies do not typically release detailed data about their particular test strips operation. Some devices apparently watch the current after a short initial transient (the current will level out to some degree) and then report this steady state current after a fixed time. Another principle looks at the total amount of reaction which has occurred and thus integrates the current with respect to time to obtain the total amount of chemical reaction which has occurred. The basic principles you will learn in this lab are common to a number of electrochemical detection sensors which are common in biochemistry.

We will use a particular test strip, the [One Touch Ultra](#). We will try looking at two measurements and see which relates to glucose level more strongly, one is the "steady-state" current and the other is total integrated current. We will build the circuit in stages, testing each piece as we go along. **Different than in prior labs, we will leave some resistor values unspecified and you will need to decide which values to use. Also, we will be less specific about exactly what you should do to test things. Starting this week, we will start intentionally being less specific about what steps to perform and what data to report in your lab write-ups.**

Step 1: Create the voltage source.

The applied voltage across two of the electrodes electrodes that we will want to fix is about -400 mV. Since, as in previous labs, we will use 2.5 as our reference (or zero) we will need to create a voltage source of about 2.1 volts (measured relative to ground). Select two or more resistors to make a voltage divider that will provide about 2.1 volts. You can use more than two resistors if we do not have a convenient value. For example, say you wanted an 11 K resistor and we did not have that value – you could place a 1K and 10K in series. You can also adjust a resistance downward by a small amount by adding a large resistor in parallel as in Lab 2. Build the circuit below with your choices of R1 and R2 (or other resistors). Check that the output of the op-amp is providing 2.1 Volts. **In your lab report draw the circuit with appropriate values of resistance that you used to create your 2.1 volt source.**

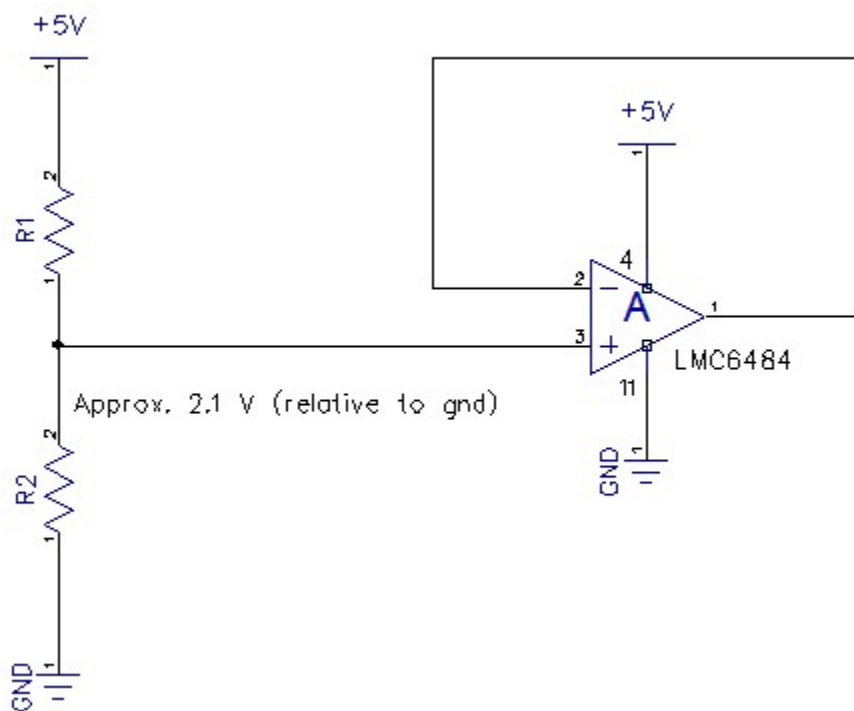

Step 2: Measure resistance

Now add to your circuit to create the circuit below. Note that since we are using the same chip for the different op-amps, we placed the power connection for the op-amp in the lower left corner of the schematic. The circuit diagram becomes a little simpler if we don't draw the power on every op-amp.

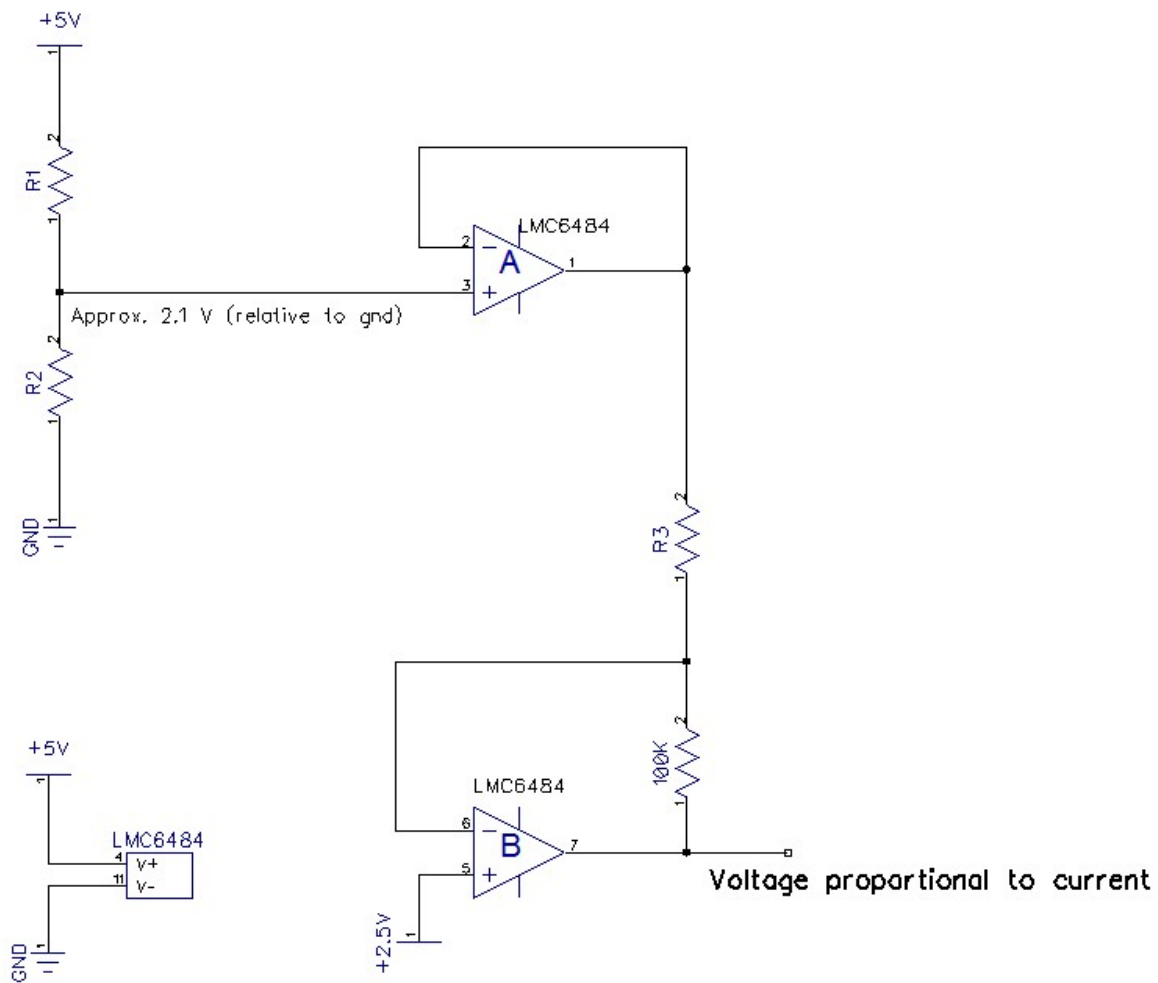

The above circuit can be used as a resistance meter, if R_3 is unknown. The voltage at the negative input of op-amp A is 2.1 V and the voltage at the negative input of op-amp B is 2.5 V (remember our op-amp rule about inputs being equal?). Therefore, -400 mV (though the exact value will depend on your selection of R_1 and R_2) is applied across resistor R_3 . This known voltage drop will have an associated current flowing through R_3 . The current flowing through R_3 must be the same as that flowing through the 100K resistor (since no current can go into the op-amp inputs). If we measure the voltage at the output of op-amp B relative to 2.5 V, we can easily infer the current flowing through the 100K resistor (twinkle, twinkle, little star... $V=iR$). Since the current flowing through R_3 is now measured, and the voltage across it is set we can calculate the value of R_3 . Build the circuit and test it with a few values of R_3 . Note that if R_3 is too small (relative to 100K) the op-amp will saturate. **Report the results of your resistance testing. Convince us the circuit works and you understand how/why. For fun, see if you can measure the resistance through your body.**

Step 3: Build an integrator

The following circuit integrates the input voltage with respect to time.

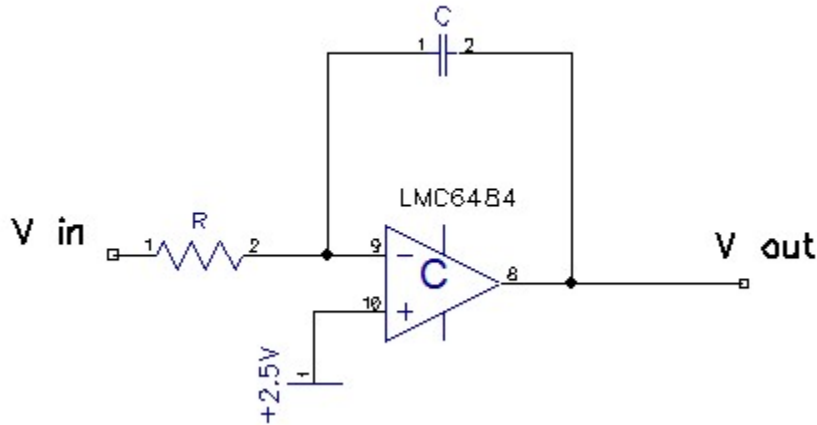

To see that this circuit integrates, just use all our laws for the resistor, capacitor, and op-amp.

Our op-amp rules tell us the voltage on the negative input must be the same as the positive input. Therefore, the voltage at the negative input is 2.5. Ohm's law says that the current through the resistor is $\frac{V_{in}-2.5}{R} = i$. Since the input to the op-amp draws no current, this is the same amount of current flowing through the capacitor. Since the capacitor law is: $i = C \frac{d(2.5-V_{out})}{dt} = -C \frac{dV_{out}}{dt}$, then

$$V_{out} - V_{out}(t = 0) = \frac{1}{RC} \int (V_{in} - 2.5) dt$$

The output voltage is related to the time integral of the input voltage, though we have to be careful that with integrators, the initial state of the capacitor matters.

Build the integrator circuit with a 100K resistor and 1 μ F capacitor. Test the circuit by using your Waveform generator as the input voltage. Test with a low frequency square wave. The square wave should be centered at 2.5 volts (adjust the offset) and you may want to experiment with changing the amplitude. Monitor the input and output voltage with the Scope on your Analog Discovery and prove that this circuit is a reliable integrator (i.e. squares integrate to triangles). Note that the frequency you select should be slow enough that there is sufficient time for the integrator to completely "fill up" and reach either the 0 or 5 volt rail during each cycle. The circuit will work fine at higher frequencies, though small amounts of noise can cause the integrator to drift on a slow time scale – so it is easier to get it to work if you saturate the integrator each cycle. **Provide one snapshot of this experiment to show that the integrator works. You decide exactly what you want to show.**

Final circuit: The glucose sensor.

Now, we will put these pieces together and plug in the glucose sensor. This circuit is just combining the pieces you already built. Note the changes. Resistor R3 was removed and will be replaced with the wires coming from the test strip connector. The test strip will stand in for the resistor. We added a small capacitor in parallel to the 100K resistor – this adds a bit of low-pass filtering and provides a smoother signal. Finally, the capacitor value on the integrator was changed to 100 uF.

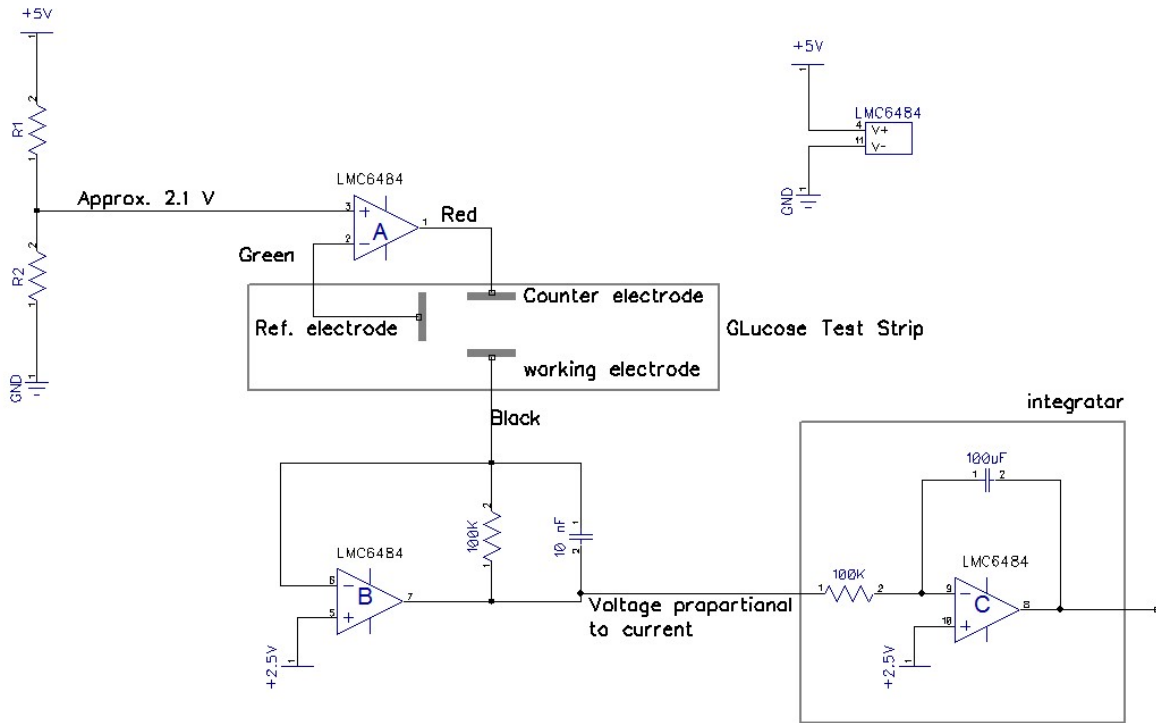

The principle with the test strip is common for electrochemical measurements. Electrochemical measurements usually use three electrodes, named the counter, working and reference electrode. Current flows between the counter and working electrode. The reference electrode is held at a known potential with no current. The reference electrode fixes the potential of the liquid on the test strip. If you recall our op-amp rules, you will see that the reference electrode is held at 2.1 volts and the working electrode is at 2.5 volts. Thus the reference electrode is -400 mV lower than the working electrode. Our circuit then monitors the current flow between the counter and working electrodes. If we measure the voltage at the output of op-amp B we get a signal proportional to current and if we monitor the output of op-amp C we see a voltage proportional to the integral of the current. **NOTE: in order to test the integral, you need to reset the capacitor voltage to zero by shorting out the capacitor with a small piece of wire or a small resistor.**

Final test: the glucose experiment

At this point you have tested your circuit in pieces, thus you really only need to be careful to note that you have plugged the proper wires from the glucose test strip connector in the right place. Note that the red, green, and black wires are attached to the counter, reference, and working electrodes respectively. We have limited test strips (they are not super cheap), thus each student can use 6. No more, please. If something doesn't work perfectly and you don't get 6 good measurements, then don't panic or worry. However, if the first experiment doesn't work, don't just try another strip expecting a different result.

The test strips look like the picture below. The sample loads on the left and by touching a droplet, the liquid will wick in automatically. The electrodes are inside the little box on the far left. The black lines on the right are the connections to the electrodes. The black lines printed on the paper are conductive. The electrode connections from top to bottom are Reference, Counter, and Working.



The piece connected to the working electrode complicate our connection, so we will just clip it off. Using a pair of sharp diagonal cutters, clip the test strip as follows,



So your strip looks like this picture below. Peel back a little bit of the blue covering near the electrode connections in order to expose a larger area of the three black stripes. Don't force it, just peel back the little bit of blue that is not glued down.



When you are ready to test and have clipped your 6 test strips,

- Place your Scope measurements at the output of op-amps B and C. Measure relative to 2.5 volts.
- Set the time scale to 4 seconds per division
- Set the voltage scale for each channel to 500 mV per division.
- Make sure the Scope's voltage offset is zero for both channels.
- Take a glass slide (wipe off any liquid from a prior experiment) and pipette a small droplet on the slide. **Make sure not to contaminate the stock solution and use a clean pipette.**
- Reset your integrator by shorting out the 100 uF capacitor with a wire.
- Hold the test strip against the connector and squeeze. The pattern on the test strip must mate with that on the connector. Yes, this is a little hokey but it seems to work. You need to be careful though that the electrodes are aligned and making good contact with the connector.
- Refresh the scope screen by hitting "stop" then "run" (or just wait until the screen loops around).
- Touch the test strip to the droplet.
- The current should rise and then decay over the course of several seconds. After about 20 seconds since touching the fluid has passed, hit stop and export the data. Since a whole screen will last for 40 seconds you have 20 seconds of margin to conduct the experiment and stop the scope before the data scrolls back over itself!
- Repeat for different glucose concentrations. Since we have limited strips, if you mess one up don't panic. Just get as many good data captures as possible.

For your lab report, show current as a function of time for different concentrations, all superimposed on one plot. Also, create a calibration curve for glucose concentration. Try plotting the current after a fixed amount of time has passed (20 seconds seems to work and is in-line with what some commercial systems do) as a function of concentration. Also try plotting the integral of current (after subtracting off the initial state) after 20 seconds versus concentration.

This is a new lab, and we are not 100% sure what works best. We had good luck getting a clear calibration with these two measures, though it is not a linear relationship. The results are a little sensitive to the hand connection, so if some of your data come out a little off that is fine.